

# The Dipole Fusion Confinement Concept:

A White Paper for the Fusion Community

J. Kesner and L. Bromberg

*MIT Plasma Science and Fusion Center*

*Cambridge, MA 02139*

M. Mauel and D. Garnier

*Department of Applied Physics, Columbia University*

*New York, NY 10027*

J. M. Dawson

*Department of Physics, UCLA*

*Los Angeles, CA 90024*

April 6, 1998

## 1 Introduction

The dipole magnetic field is the simplest and most common magnetic field configuration in the universe. It is the magnetic far-field of a single, circular current loop, and it represents the dominant structure of the middle magnetospheres of magnetized planets and neutron stars. The use of a dipole magnetic field generated by a levitated ring to confine a hot plasma for fusion power generation was first considered by Akira Hasegawa after participating in the Voyager 2 encounter with Uranus [1]. Hasegawa recognized that the inward diffusion and adiabatic heating that accompanied strong magnetic and electric fluctuations in planetary magnetospheres represented a fundamental property of strongly magnetized plasmas not yet observed in laboratory fusion experiments. For example, it is well-known that global fluctuations excited in laboratory fusion plasmas result in rapid plasma and energy loss. In contrast, large-scale fluctuations induced by sudden compressions of the geomagnetic cavity (due to enhancements in solar wind pressure) or by unsteady convections occurring during magnetic substorms energize and populate the energetic electrons trapped in the Earth's magnetosphere [2]. The fluctuations induce *inward* particle diffusion from the magnetospheric boundary even when the central plasma

density greatly exceeds the density at the edge. Hasegawa postulated that if a hot plasma having pressure profiles similar to those observed in nature could be confined by a laboratory dipole magnetic field, this plasma might also be immune to anomalous (outward) transport of plasma energy and particles.

The dipole confinement concept is based on the idea of generating pressure profiles near marginal stability for low-frequency magnetic and electrostatic fluctuations. For ideal MHD, marginal stability results when the pressure profile,  $p$  satisfies the adiabaticity condition,  $\delta(pV^\gamma) = 0$ , where  $V$  is the flux tube volume ( $V \equiv \oint dl/B$ ) and  $\gamma = 5/3$ . This condition leads to dipole pressure profiles that scale with radius as  $r^{-20/3}$ , similar to energetic particle pressure profiles observed in the Earth's magnetosphere. Since the magnetic field of a dipole is poloidal, there is no drift off of flux surfaces and therefore no "neo-classical" degradation of confinement as seen in a tokamak. It has been pointed-out that a plasma that satisfies the MHD interchange stability requirement may be intrinsically stable to drift frequency modes. Stability of low frequency modes can be evaluated using kinetic theory and a Nyquist analysis permits an evaluation of stability boundaries with a minimum of simplifying assumptions. Using kinetic theory we have shown that when the interchange stability requirement (for small Larmor radius) becomes  $\omega_{*p} > \omega_p$  with  $\omega_{*p}$  the diamagnetic drift frequency and  $\omega_d$  the curvature drift frequency and this result is consistent with MHD[3]. This property implies that the pressure scale length exceed the radius of curvature, which is a physical property that distinguishes a dipole confined plasma from other approaches to magnetic fusion plasmas. Additionally, when the interchange stability criterion is satisfied, it can be shown that localized collisionless trapped particle modes and dissipative trapped ion modes become stable. Low frequency modes that are driven by parallel dynamics (*i.e.* the universal instability) also tends to be stable due to the requirement that the parallel wavelength of the mode fit on the closed field lines. Recent theoretical work on anomalous inward diffusion (towards the ring) due to high frequency, drift-cyclotron instability supports the view that both stability and confinement can be extremely good in a levitated dipole [4].

By levitating the dipole magnet end losses can be eliminated and conceptual reactor studies supported the possibility of a dipole based fusion [5, 6] power source that utilizes advanced fuels. The ignition of an advanced fuel burning fusion reactor requires high beta and good energy confinement. Additionally advanced fuels require steady state and efficient ash removal. A levitated dipole may provide uniquely good properties in all of these areas. The chief drawback of the dipole approach is the need for a levitated superconducting ring internal to the plasma and this provides a challenge to the engineering of the device. A fusion reactor based on a levitated dipole has been explored in two studies [5, 7]. Recent advances in high temperature superconductors coupled with an innovative design concept of Dawson [8] on the maintenance of an internal superconducting ring in the vicinity of a fusion plasma lead us to believe that this issue is technologically solvable.

The dipole confinement approach can be tested in a relatively modest experiment which profits from the development of the technology of superconductors, gyrotrons and pellet injectors. A concept exploration experiment is presently being developed jointly by Columbia University and MIT.

## 2 Scientific State of Concept

The conceptual development of the dipole fusion concept has been inspired by space plasma studies and planetary exploration. A number of authors have explored the MHD properties of a high beta plasma confined in a dipole field from the space plasma perspective [11, 12]. We expect that continued exploration of magnetospheric plasmas (for example, the exploration of the Io plasma torus that surrounds Jupiter and the development of physics-based models of space weather) will add to the cross-fertilization of this area of plasma science.

There is also a small but significant literature on dipole confinement specifically addressing plasmas leading to possible fusion energy production. The stability of drift frequency modes has been explored by Hasegawa and co-workers [5] and by Kesner [3]. Hasegawa, Chen, and Mauel [1, 5] have made initial explorations of dipole fusion power sources. Teller and co-workers [7] developed a conceptual design of a levitated dipole space propulsion system. Pastukhov and Sokolov [4] have developed theories of thermal transport to the levitated ring when the surrounding plasma fully recycles neutrals. Convective cells are expected to be present in the plasma [9] and particle-in-cell (PIC) simulations indicate that convective cells can play an important role in maintaining marginal pressure profiles [10].

Although the dipole plasma confinement concept is a radial departure from the better known toroidal-based magnetic confinement concepts, a scientific investigation of magnetized plasma confinement with high compressibility will add insight to these other more traditional confinement concepts. For example, Isichenko and co-workers [21] have used “stationary” marginally-stable profiles to derive a theoretical description for the inward anomalous pinch in tokamaks. The influence of compressibility on the tokamak temperature profile is not well understood; however measurements from circular L-mode plasmas show a relationship between the temperature profile and the flux-tube volume,  $T \sim (1/q)^2$  [22, 23] suggesting a profile consistency based on the flux tube geometry. (For a large-aspect ratio tokamak,  $V(\psi) = \oint dl/B \sim 1/q$ .) Kesner [3] has observed the importance of compressibility in the outer flux surfaces of spherical tori.

Finally, there exists some laboratory observations relevant to the dipole concept. Observations of plasma stabilized by compressibility were made by Ferron and co-workers [24] in the UCLA Large Axisymmetric Mirror Experiment (LAMEX). When peaked plasma profiles were generated in this device, MHD interchange stability was observed over the entire radius of the device, and the observed stability could only be attributed to plasma compressibility with  $\gamma = 5/3$ . The CTX device at Columbia University has illustrated the stability properties of collisionless energetic electrons confined by a dipole magnetic field [13, 14, 15]. In this experiment, hot electron interchange instabilities are observed only for finite radial phase-space gradients,  $\partial F/\partial\psi > 0$ , which significantly *exceeds* the marginally stable profiles for MHD interchange.

Together, this scientific literature for the dipole confinement includes space-based observations and theory, laboratory experiments, and theory which establishes a bridge from collisionless dipole confinement observed in planetary magnetospheres to the collisional

fusion regime appropriate for levitated dipoles in the laboratory. This work provides strong encouragement for the consideration of a levitated dipoles as the basis for a new and unique fusion confinement device.

### 3 Optimum Path for development

An essential first step for the understanding of the scientific feasibility of a levitated dipole is a laboratory test of confinement properties of such a device. We are completing the design of an experiment to test the scientific feasibility of levitated dipole confinement at high beta. This experiment, referred to as the Levitated Dipole Experiment (or LDX), is being designed as a joint project between Columbia University and MIT.

The primary objective of the experimental program is to investigate the confinement properties of a steady-state plasma confined in a dipole field. In particular we will investigate the possibility of supporting a plasma with high beta and near classical confinement. The experimental program will also focus on the following questions:

- The study of high beta plasma stabilized by compressibility.
- The relationship between drift-stationary profiles having absolute interchange stability and the elimination of drift-wave turbulence.
- The coupling between the scrape-off-layer and the confinement and stability of a high-temperature core plasma.
- The stability and dynamics of high-beta, energetic particles in dipolar magnetic fields.
- The long-time (near steady-state) evolution of high-temperature magnetically-confined plasma.

The proposed LDX experiment has been conceived as the lowest cost experiment to investigate the key physics issues of high-beta dipole confinement while simultaneously maintaining high confidence of its technical success. Careful consideration of several options for plasma formation, plasma heating and ring levitation or support led to the selection of a superconducting ring with the high beta plasma heated by ECRH. The experimental approach takes two stages. First, multiple frequency ECRH (with frequencies between 6 and 28 GHz) will be used to produce a population of energetic electrons at high  $\beta \sim 1$ . This technique has been proven effective in magnetic mirror experiments (*e.g.* Constance and Tara [25]), but the production of a high beta plasma in a dipole field requires the levitation of the internal ring in order to avoid end losses at the supports. Based on our experience generating hot electrons within mirrors [25] and within CTX, we expect to create and sustain high beta plasmas using a few 10's of kW of ECRH power. Secondly, after formation of the high  $\beta$  hot electron plasma, fast deuterium gas puff techniques or the injection of lithium pellets [16] will be utilized to thermalize the

## LDX Base Case Configuration

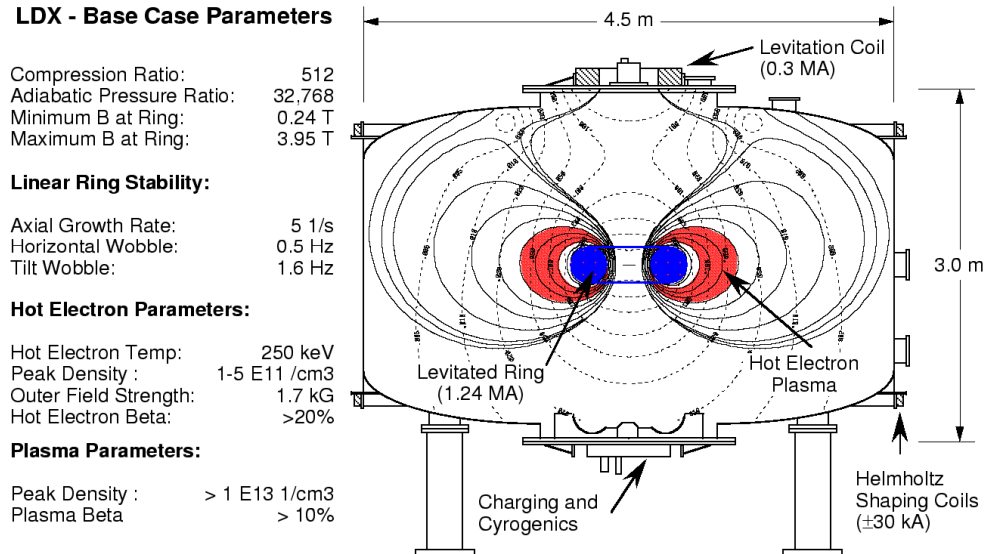

Figure 1: Cross-section view of the proposed LDX experiment showing the basic flux configuration resulting from ring levitation with a single external coil. Magnetic field lines (solid) and  $|B|$  contours (dotted) are shown.

energy stored in the hot electrons and to raise the plasma density. The resulting thermal plasma will provide a test of the MHD limits and the confinement of a thermal plasma in a levitated dipole.

Consider, for example, a dipole plasma heated at the 0.2 T resonance surface (10 to 50 kW of CW power) we may expect to produce a hot electron plasma with  $n_e \sim 3 \times 10^{17} m^{-3}$  at 200-300 keV ( $\beta \sim 0.5$ ). The ability to transfer the energy depends on the competition of cross field transport and thermalization of the hot electron energy. For classical confinement, a large fraction of the energy could be transferred and a we could obtain a hydrogenic plasma with  $T_i > 200$  eV and  $n_e \sim 10^{19} m^{-3}$ . Thus, by combining ECRH and pellet injection a modest dipole experiment might be capable of investigating the properties of high temperature, high density, and high beta plasmas.

Once we are satisfied that good confinement at high beta is achievable in a levitated dipole it would be appropriate to move to a “proof of principle” experiment. At this stage we would attempt to generate near ignition plasma parameters and to test the compatibility of the configuration with different heating and fueling schemes. We would also test plasma confinement under steady state conditions.

## 4 Special Enabling Technologies

A levitated dipole confinement device consists of a small superconducting ring that floats in a relatively large vacuum chamber. Superconducting technology is therefore critical for this concept. Much of the heat that is incident onto the surface of the ring (either from particles or radiation) is expected to be radiated from the ring surface to the vacuum chamber wall. There is some heat leak into the superconductor and in a laboratory experiment the superconductor can be levitated for several hours before re cooling. In a reactor environment an inertially cooled ring could float for tens of hours. It has also been proposed that the ring in a reactor could contain internal refrigerators [8] and as a result the operation could be steady state.

The development of high temperature superconductors would substantially ease the difficulty of designing the internal ring. A high  $T_C$  (high critical temperature) coil would have an increased heat capacity and could be maintained for a relatively long pulse without the need for internal refrigerators. Furthermore a refrigerated steady state coil would be substantially easier to design using a high  $T_C$  superconductor. As already discussed, the laboratory development of this research path profits from technology advances in the areas of gyrotrons for electron heating and pellet injectors for fueling.

## 5 Potential Advantages Relative to a Tokamak

The dipole reactor concept is a radical departure from the better known toroidal-based magnetic fusion reactor concepts. For example, the most difficult problems for a tokamak reactor are the divertor heat dissipation, disruptions, steady state operation, and an inherently low beta limit. Furthermore, the tokamak is subject to neoclassical effects and, in many cases, anomalous, fluctuation-induced transport. The dipole concept provides a approach to fusion which solves these problems.

- *Divertor problem:* The difficulty in spreading the heat load at the divertor plate is generic to concepts in which the magnetic flux is trapped within the (toroidal field) coil system. By having the plasma outside of the confining coil the plasma flux can be sufficiently expanded to substantially reduce divertor and first wall heat loads.
- *Major disruptions:* A tokamak has a large amount of energy stored in the plasma current. The dipole plasma carries only diamagnetic current and is inherently free of disruptions. Furthermore there is evidence that when the dipole becomes MHD unstable, i.e.  $\nabla p > \nabla p_{crit}$ , the plasma will expand sufficiently to reduce the pressure gradient (much like tokamak type I ELMs). Therefore MHD instability will not lead to a loss of plasma.
- *Steady state:* A tokamak is a pulsed device and current drive schemes that are required for steady operation appear to be costly. The dipole plasma is inherently steady state.

- *Beta limits:* Tokamak stability depends on the poloidal field which is less than the toroidal field by  $B_p/B_T \sim a/qR$  and  $\beta_{pol} \sim 1$  determines a beta limit  $\beta \ll 1$ . For a dipole there is a critical pressure gradient that can be supported and for a sufficiently gentle pressure gradient the dipole plasma resides in an absolute energy well and is stable up to local beta values in excess of unity.
- *Transport and neoclassical effects:* The trapping of particles in regions of bad curvature makes the tokamak susceptible to drift frequency range turbulent transport. A dipole can, theoretically, be stable to low frequency drift modes [1, 3].

In addition a tokamak has a “neoclassical” degradation of transport that derives from the drifts of particles off of the flux surfaces. In a dipole the drifts are toroidal and they define the flux surfaces. Therefore the irreducible minimum transport for a dipole is governed by the “classical” and not the “neoclassical” limit.

- *Fueling:* Fueling and ash removal are an important issue in an ignited reactor and are of particular importance for operation with advanced fuels which deposit all of the fusion products within the fusing plasma.

Magnetic confinement configurations that do not have shear may be subject to convective cells [9, 18]. At the critical pressure gradient for marginal stability the resulting convective flows can transport particles without a net transport of energy, i.e. the hot core plasma cools as it convects outwards and the outer plasma heats as it convects inward. This would provide the ideal approach for fueling a reacting fusion plasma.

The dipole reactor would also provide significant and significantly different engineering challenges from a tokamak. The outstanding issues are the sustenance of a superconducting coil embedded within a fusing plasma. This issue plus the advantages listed above such as high beta, good confinement and improved fueling makes the dipole concept particularly well suited for advanced fuels. The use of warm (high  $T_C$ ) superconductors and the development of creative ideas for internal refrigerators [8] would greatly enhance the feasibility of this approach.

## 6 Advanced Fuel Burner

Advanced fuels burners would require near-classical confinement of high beta plasmas. The high fraction of energy that is produced in charged particles aids in ignition but increases the rate of ash buildup and requires the development of efficient scheme for ash removal and fueling. On the other hand advanced fuels offer substantially reduced neutron output and therefore may permit the utilization of internal rings within the fusing plasmas. These considerations make a dipole an ideal candidate for an advanced fuel burner. Much work remains to be done to evaluate the compatibility of a dipole configuration with advanced fuel reactors. One fuel cycle that is desirable because of the

abundance of fuel is the DD cycle. An other interesting fuel cycle would utilize D and  $^3\text{He}$ . However, since  $^3\text{He}$  does not occur naturally in sufficient quantity on the earth, the utilization of the D $^3\text{He}$  cycle (on the earth) would require the mining and transportation of  $^3\text{He}$  from the moon.

## 7 National and International Collaborations

The LDX experiment is being built as part of a collaboration between MIT and Columbia University, with significant input from PPPL. There is a wide spread interest in the theoretical aspects of confinement in a dipole configuration, including theory groups at UCLA, U. Maryland and IFS at U.T. Austin. Internationally there is an active interest in the physics of dipole confinement in Japan which includes Hasegawa, and we are investigating a collaboration with Japanese counterparts. Additionally there is an ongoing research effort in internal ring devices at Kurchatov in Russia.

## 8 Conclusions

The dipole confinement was inspired by the observations of naturally occurring magnetically-confined high-beta plasmas and from advances in space plasma physics. The dipole approach represents a significant departure from toroidal confinement schemes that enclose the flux tube within toroidal field coils and utilize rotational transform for gross stability. In addition to space plasma physics research, the physics of dipole confinement profits from prior experience with magnetic mirrors, internal rings, and EBT confinement studies.

A concept exploration experiment is presently being designed and built as a joint project of Columbia University and MIT.

## References

- [1] A. Hasegawa, *Comm Pl Phys & Cont Fus*, **1**, (1987) 147.
- [2] A. L. Vampola, *1. Symp. on Natural and Manmade Rad. in Space* p. 538, (Wash., D.C., 1972).
- [3] J. Kesner, *Phys. Plasmas* **4** (1997) 419.
- [4] V. Pastukhov and A. Yu. Sokolov, *Nuc. Fusion* **32** (1992) 1725.
- [5] A. Hasegawa, L. Chen and M. Mauel, *Nuclear Fus.* **30**, (1990) 2405.
- [6] A. Hasegawa, L. Chen, M. Mauel, H. Warren, S. Murakami, *Fusion Technology* **22** (1992) 27.
- [7] E. Teller, A. Glass, T.K. Fowler et al., *Fusion Technology* **22**, (1992) 82.
- [8] J. Dawson, Private communication, see Ref. [7].
- [9] J. M. Dawson, H. Okuda and R. Carlile, *Phys. Rev. Lett.* **27** (1971) 491
- [10] H. Goede, D. Humanic, J. Dawson, *Phys Fluids* **26**, (1983) 1812.
- [11] E. Hameiri et al., *J. Geophys. Res.*, **96** (1991) 1513.



- [12] A. Chan, M. Xia and L. Chen, *J. Geophys. Res.*, **99**, (1994) 17351.
- [13] H. P. Warren and M. E. Mauel, *Phys. Rev. Lett.* **74** (1995) 1351.
- [14] H. P. Warren and M. E. Mauel, *Phys. Plasmas* **2**, 4185 (1995).
- [15] H. P. Warren, M. E. Mauel, D. Brennan, and S. Taromina, *Phys. of Plasmas* **3** (1996) 2143.
- [16] O .A. Anderson, *et al.*, in *Plasma Physics and Controlled Nuclear Fusion* (IAEA, Vienna, 1972) Vol. 1, 103.
- [17] See reports describing design and operation of FM-1 in *Proceedings, Fourth Symposium on Engineering Problems of Fusion Research*, (NRL, Washington, D.C., April 20-23, 1971) I.E.E.E., New York, pp. 83-101, 273-290, and 351-380.
- [18] G. Navratil, R.S. Post and A. Butcher Ehrhardt, *Phys Fluids* **20** (1977) 157.
- [19] R. Freeman, *et al.*, “Confinement of plasmas in the spherator”, in *Plasma Physics and Controlled Nuclear Fusion Research* (IAEA, Vienna, 1972) Vol. 1, 27.
- [20] M. Okabayashi, *et al.*, *Phys. Fluids* **16** (1973) 1337.
- [21] M. B. Isichenko, A. V. Gruzinov, and P. H. Diamond, *Phys. Rev. Lett.* **74** 4436 and M. B. Isichenko, A. V. Gruzinov, and P. H. Diamond, and P. Yushmanov, *Phys. Plasmas* **3** (1996) 1916.
- [22] T. Ohkawa, *Comments on Plasma Physics and Controlled Fusion*,**9** (1985) 127-38.
- [23] B. Coppi, *Comments on Plasma Physics and Controlled Fusion*,**5** (1980) 261.
- [24] J. R. Ferron, *et al.*, *Phys. Fluids* **26** (1983) 2227.
- [25] R. C. Garner, M. E. Mauel, S. A. Hokin, R. S. Post, D. L. Smatlak, *Physics of Fluids* **B 2**, 242 (1990).
- [26] T. Jernigan, J. Rudmin and D. Meade, *PRL* **26** (1971) 1298.
- [27] J. Kesner and M. Mauel, “Plasma Confinement in a Levitated Dipole”, *Plasma Physics Reports*, (1997).